



seriemega^{HP}

Injection Molding Machines from Sandretto do Brasil with Automata Control Systems: sercos Establishes Itself in the Plastics Machinery Industry

Mega series machine from Sandretto do Brasil

Sandretto do Brasil is one of South America's leading manufacturers of injection molding machines. The company's main strength is its use of innovative automation technology that takes the special cost situation on the local market into account. The most important specifications while creating the design of the new Meglio und Mega machine series were standardization of the control components by implementing an open and future-oriented system bus and an increase in machine performance. Another goal was to substantially reduce costs for electrical equipment in the machine. The F3 control system from Automata with a sercos communication bus perfectly fulfills the technical requirements. A further plus: besides its improved system performance it also reduces costs in comparison to the previously-used solution.

Why use sercos?

Due to the modular design of injection molding machines and the substantial mechanical dimensions related to the size and weight of the workpiece to be manufactured, a field bus is commonly used to connect I/Os and drives to the central control. However, the previously-used CAN technology can no longer fulfill the requirements for transmission speed and reproducibility of various process values. As a consequence, sensors and actuators distributed throughout the machine had to be connected to the central control, even though there was a field bus. This resulted in an increase in wiring and was a contradiction to the machine's modular architecture. In such situations, sercos is the perfect solution. Thanks to short cycle times and highly synchronous sensing and activation of the inputs and outputs, all values can be transferred via the system bus. sercos' ring redundancy also provides additional transmission security. The central control no longer

needs to be equipped with local I/Os. The oversampling and probe & compare functions introduced in sercos V1.3 also offer additional options, making it possible to move monitoring of pressure and position threshold values and thereto responses to the I/O level. This takes a load off the control, enabling an increase in machine performance and, most importantly, reproducibility of the production process. Standardization of these functions were decisive factors for selecting sercos for this application. There is no need for proprietary solutions or extensive in-house development and the company remains independent from component manufacturers.

Why use F3?

The F3 control system from Automata consists of a PC-based basic unit, decentral I/Os and a series of different operating panels. The basic unit is equipped with an Intel Atom CPU and a sercos III master interface that is



Meglio series machine from Sandretto do Brasil



F3 basic unit with detailed view of sercos

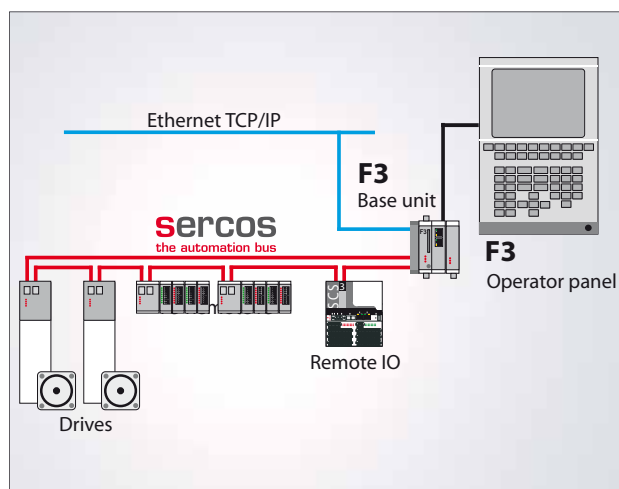

Diagram of the F3 control system

connected to the processor via PCIeexpress. This makes it easy to produce the I/O update rate and synchronicity required by the injection molding process. The control is programmed with CoDeSys in IEC 61131-3 languages. Comprehensive libraries with function modules to control the individual machine functions and configurable process sequences are available specifically for use in injection molding machinery. The visualization software is Win-MachLite from Automata, which also comes with comprehensive templates specially designed for machines that process plastics. Both of these software components and the associated extensions enable simple adaptation to the wide range of machines in the Meglio and Mega series. As a result, workpiece-specific or customer-specific adjustments can be implemented very quickly.

The F3 panel interface makes a major contribution to achieving the cost target for the new Sandretto do Brasil

machine series. To connect the control panel to the basic unit, you only need one cable for video, keyboard, touch screen, USB, power supply, buttons and lamps, making it a very inexpensive and easy solution.

In summary, the following arguments persuaded Sandretto do Brasil to use a sercos system bus:

- Fast and highly synchronous transmission of decentral process values such as pressures, closing forces and positions of the individual machine modules.
- Increase in reliability thanks to ring redundancy
- High degree of standardization even for complex functions such as oversampling and probe & compare and the ability to avoid proprietary solutions or in-house developments in the future
- Open and independent of manufacturer

These features, the performance of the control and comprehensive software libraries for injection molding applications all facilitate fast and simple introduction of the new control generation with a sercos system bus. ■

S Contact

Automata GmbH & Co. KG
 Phone +49 8233 7916-0
 Fax +49 8233 7916-99
 Inquiries: info@automata.de
 www.automataweb.com